

VERSION 1

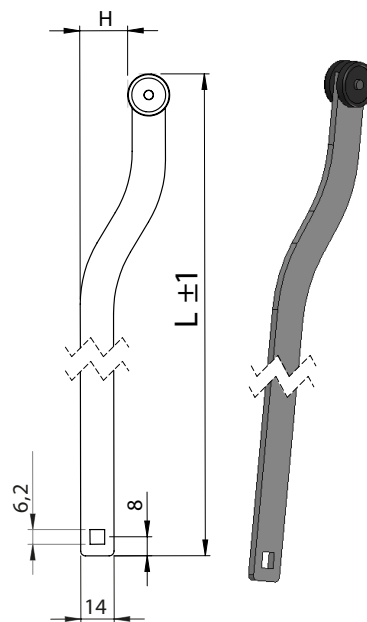

VERSION 2

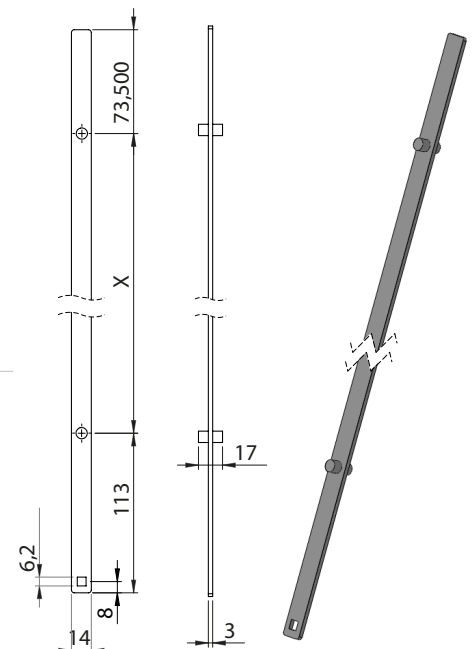

VERSION 3

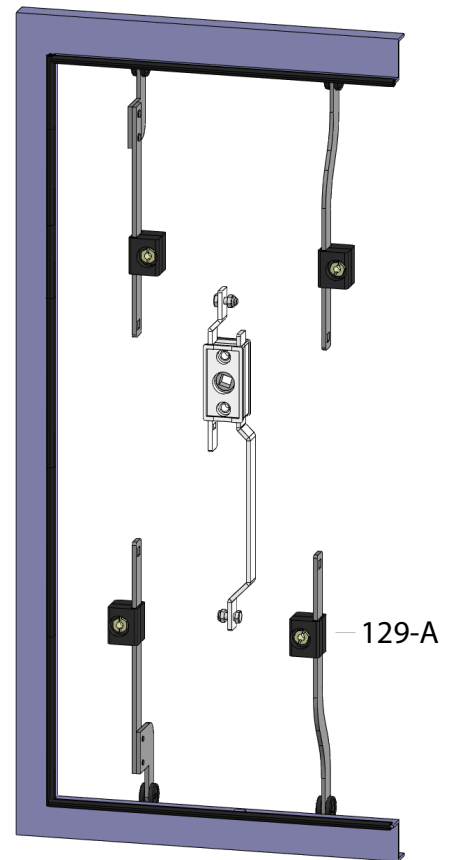

SWING HANDLES

Material	Version	Length (L)	Height (H)	Code
Steel, zinc plated Casters: Plastic	1	1020	21	129-V1-21-1020
	1	1020	38	129-V1-38-1020
	2	1020	16	129-V2-16-1020
	2	1020	21	129-V2-21-1020
	3	575	-	129-V3-575

\* All dimensions are in mm

\* Different length upon request